



Micro
Glühlampen
Gesellschaft
Menzel GmbH

SPECEFICATION

8919-726

P.O.B.800760, D-21007 Hamburg

5 V • 1 A • 3,38 cd

ROHS compliant

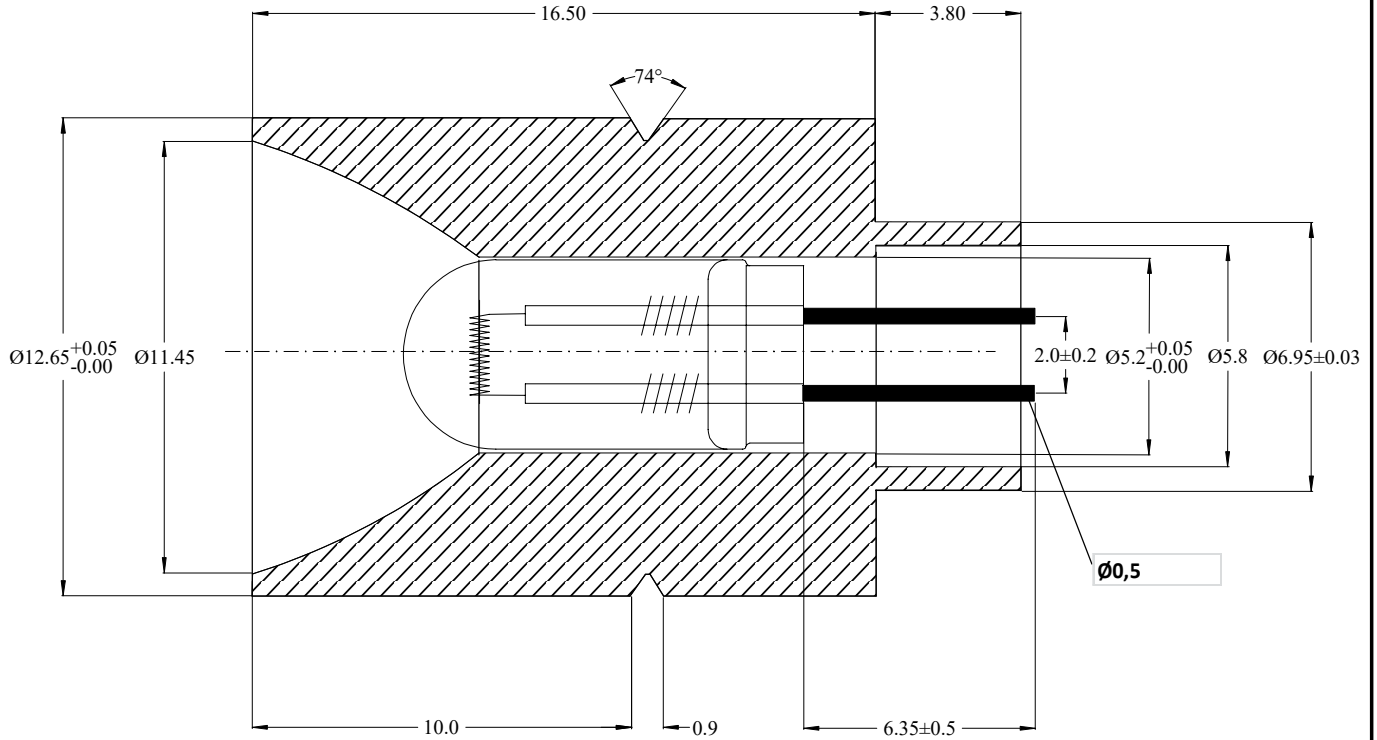

VOLTAGE		V	5		LUMINOUS INTENSITY		M.S.C.P.	3,38	
CURRENT		mA	1000		± 25 %				
±	10	%							
POWER		W	5		LUMINOUS FLUX		lm		
±	10	%			± 25 %				
LIFETIME		AC	h						
±	50	%	DC	h					
REF.-NO.				-	FILAMENT		C-6 (A)		
CAP				-	LEADS				
MARKING					WEIGHT (KG/1000 pcs.)				
BASE				-	TYPE OF GAS		Xenon		
DIVERS					SCALE:	SIZE:			
					APPR.-BY:	Hassdenteufel	DRW.-BY:		Frühhaber
					Date			18.04.2019	